

NF-1200A Pneumatic Driven Ambient Air Breathing Pump

The pneumatic driven ambient air breathing pump is designed for use in unsuitable respiratory areas / job sites. The breathing pump is a portable, pneumatic driven low-pressure pump which provides breathable air through a intake filter assembly.

FEATURES AND BENEFITS

- HEPA rated inlet and outlet air filtration ensures removal of airborne particles
- Supplies breathable air to operate up to two constant flow, type C, NIOSH approved RC-80 respirators
- Respirator mask includes a built-in speaking diaphragm for better communication.
- Designed specifically for personnel that enter aircraft fuel tanks for inspection or repair.
- Box Of 10 Replacement Filter Cartridges For Air Pump
- 100 ft. Inlet compressed air hose assembly with quick disconnect fittings
- Lightweight and very portable, sets up quick and easy
- Impact and crush resistant reusable container

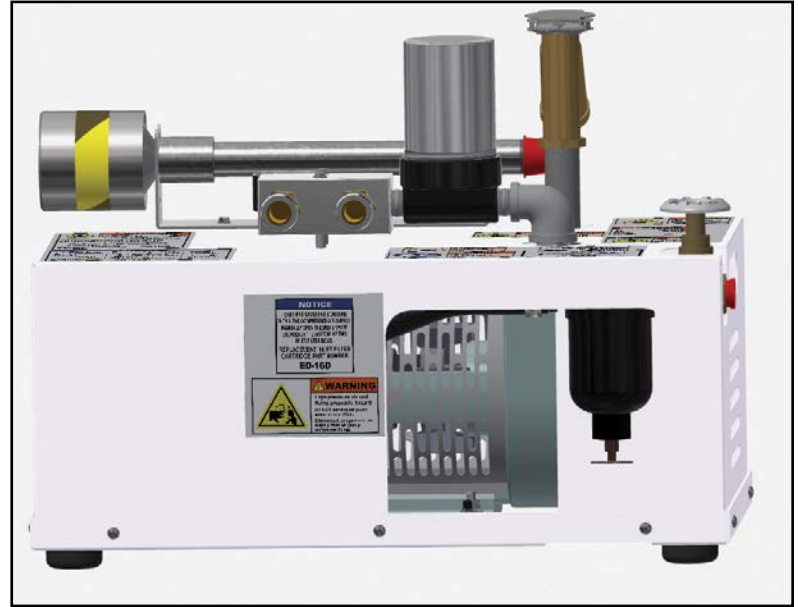

SPECIFICATIONS

Classification:	Pneumatic Driven Ambient Air Breathing Pump
Compressed Air Supply Requirements:	Pressure: 110 psig (7.6 bar)
Air Filtration:	HEPA rated
Air Pressure Gauge:	0-15 psi
Pressure Relief Valve:	Factory set to 15 psi
Filter Service Interval:	70 - 100 hours of run time

PART

DESCRIPTION

NF-1200A	AERIAL Pneumatic Driven Ambient Air Pump
----------	--

Berry Compliant and Made In U.S.A.